

# UL Listed 42 Bar FK-5-1-12 Clean Agent System

## Fire Suppression System

### General Information

FK-5-1-12 Clean agent system are employed to protect critical installations formerly protected by Halon 1301.

### These include :-

- Data Processing Centers
- Telephone Switches
- Process Control Rooms
- Art and Historical Collections
- Archive & Museums
- Marine, Oil & Gas
- Aerospace, Aviation & Military

### FK-5-1-12 Fire Suppression Agent

#### Part Number – H2-120-000

FK-5-1-12 agent complies with NFPA Standard 2001 : standard for Clean Agent fire Extinguishing systems, EPA SNAP Program (Significant New Alternate Policy)

These agents are classified as suitable for use in occupied areas and are considered to have no ozone depleting potential (ODP)

FK-5-1-12 fire suppressant can be safely used where people are present.

### DESCRIPTION

FK-5-1-12 systems reach extinguishing levels in 10 seconds or less, stopping ordinary combustibles, electrical, and flammable liquid fires before they cause significant damage. That's the fastest fire protection available, period. When fire is extinguished this quickly, it means less damage, lower repair costs, and an extra margin of safety for people. It also means less downtime and disruption of business.

### PHYSICAL & CHEMICAL PROPERTIES

Empirical formulae..... $CF_3CF_2C(O)CF_3)_2$   
 IUPAC Designation .....Dodecafluoro-2-methylpentan-3-one  
 ASHRAE Designation.....FK-5-1-12  
 Molecular Weight.....316.04  
 Boiling Point at 1 Atm.....49.2 °C (120.6 °F)  
 Freezing Point.....-108.0°C (-162.4°F)  
 Ozone Depletion Potential.....0  
 Atmospheric Lifetime.....5 days  
 No Observed Adverse Effect Level.....10 %



AGENT	CLASS A MEC	CLASS A DESIGN	CLASS B MEC	CLASS B DESIGN	CLASS C DESIGN
FK-5-1-12	3.3	4.0	4.5	5.9	4.5
NFPA 2001 REQUIREMENTS FOR MINIMUM VALUES					

### CLASS B CONCENTRATION

FLAMMABLE LIQUID	DESIGN CONCENTRATION (VOL.%)
ACETONE	5.59
ETHANOL	7.15
N-HEPTANE	5.85
TRANSFORMER OIL	5.85
DIESEL FUEL	4.42
JP4	9.0
PRRROLIDINE	6.11

### ENVIRONMENTALLY FRIENDLY

DESCRIPTION	FK-5-1-12
OZONE DEPLETION POTENTIAL	0.0
GLOBAL WARMING POTENTIAL	1
ATMOSPHERIC LIFETIME (YEARS)	5 DAYS
SNAP (YES/NO)	YES

## 34, 80, 120 & 140 liter Capacity Seamless Cylinder - Standard Unit

PESO Approved Seamless cylinder of FK-5-1-12 Clean Agent System are used with 42 Bar (610 PSI) system.

SEAMLESS CYLINDER DATA - STANDARD UNIT					
PART NUMBER	CAPACITY	VALVE (NB)	AGENT FILL RANGE (KG.)	HEIGHT (MM)	DIAMETER (MM)
H2-42-34-000	34 L	1-1/2" (40NB)	16.4 TO 38.1	1118	Ø 232
H2-42-80-000	80 L	1-1/2" (40NB)	38.5 TO 89.7	1842	Ø 267
H2-42-120-000	120 L	1-1/2" (40NB)	57.7 TO 134.6	1642	Ø 356
H2-42-140-000	140 L	1-1/2" (40NB)	67.3 TO 157.0	1867	Ø 356

### Storage Temperature :-

FK-5-1-12 is stored in cylinder as liquid, superpressurized with dry nitrogen to 42 bar at 21°C (610 PSIG at 70 °F)

### Materials :-

Valve Body: Brass

Cylinder: Seamless type, manufactured and tested in accordance with IS 7285 Standard and approved by PESO for their use

### Notes :-

- Clean Agent Cylinder must be installed in vertical position only.
- Do not cover remove or deface caution label
- The cylinder is dispatched with protective cap (part number H4-088-000)

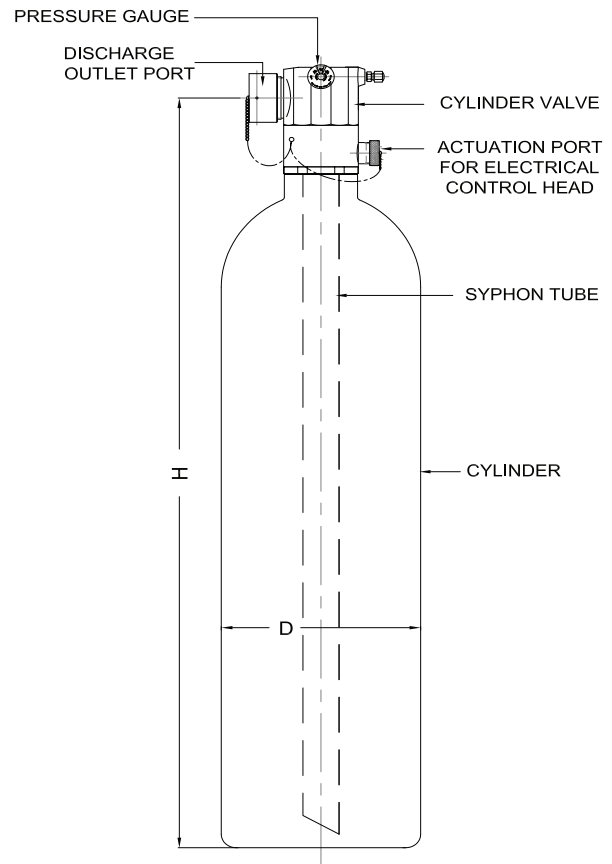

## 34, 80, 120 & 140 liter Capacity Seamless Cylinder With Switch-in-Gauge Unit

The seamless cylinder is PESO approved for 42 Bar (610 PSI) system are used with FK-5-1-12 clean agent. It is also equipped with Switch-in-Gauge unit, design to monitor health of cylinder pressure.

This 2 in 1 unit offers unique facility whereas we can monitor cylinder pressure locally and healthiness of cylinder can be monitor remotely via using Fire Alarm Panel interface unit or any other control panel.

For ordering purpose please refer part number given below. This switch will come as a package along with Cylinder Valve Assembly.

SEAMLESS CYLINDER DATA - SWITCH-IN-GAUGE UNIT					
PART NUMBER	CAPACITY	VALVE (NB)	AGENT FILL RANGE (KG.)	HEIGHT (MM)	DIAMETER (MM)
H2-42-34-002	34 L	1-1/2" (40NB)	16.4 TO 38.1	1118	Ø 232
H2-42-80-002	80 L	1-1/2" (40NB)	38.5 TO 89.7	1842	Ø 267
H2-42-120-002	120 L	1-1/2" (40NB)	57.7 TO 134.6	1642	Ø 356
H2-42-140-002	140 L	1-1/2" (40NB)	67.3 TO 157.0	1867	Ø 356

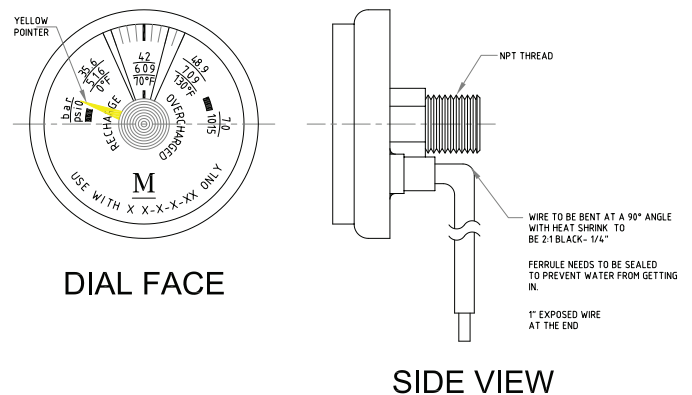

## 1-1/2" Flexible Discharge Hose

Flexible discharge hose is used to connect cylinder valve to the pipeline or the manifold of the manifold check valve.

### Technical Data :-

Hose MOC : Reinforce Rubber Hose  
 Fitting MOC : Carbon Steel

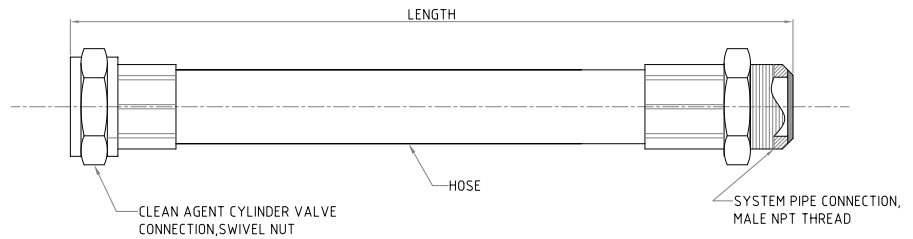

### DISCHARGE HOSE DATA FOR IS SEAMLESS CYLINDER

PART NUMBER	HOSE SIZE	CYLINDER VALVE SIZE	USE WITH CYLINDER CAPACITY	LENGTH	MINIMUM BENDING RADIUS
H4-001-000	Ø 1-1/2"	40NB	34, 80, 120 & 140 liter	23"	10.5"
H4-002-000	Ø 2"	80NB	180 liter	29"	13.5"

## Cylinder Mounting Strap

Cylinder straps are used to mount the clean agent cylinders in vertical position.

### Technical Data :-

Body : Mild Steel.

### ORDERING INFORMATION

PART NUMBER	CYL. SIZE	A	B	C	D	E	F	R
		MM	MM	MM	MM	MM	MM	MM
H4-011-000	34 L	233	330	295	39	111	Ø14	116
H4-012-000	80 L	268	365	330	39	128	Ø14	133
H4-013-000	120 & 140 L	357	454	419	39	173	Ø14	178

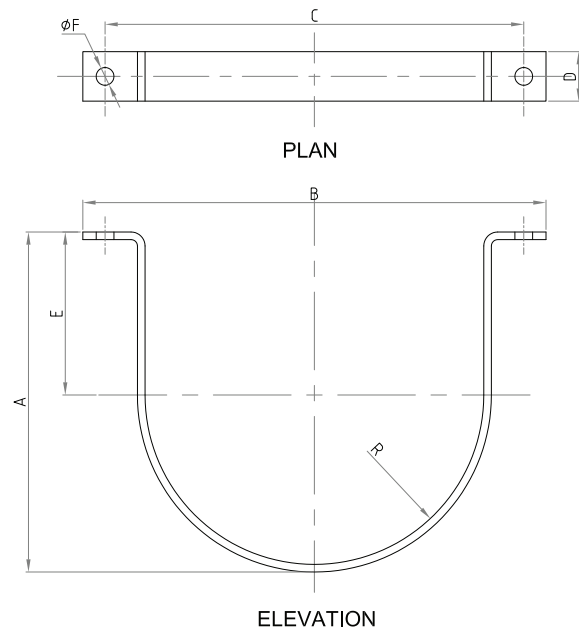

## Electric Cum Manual Actuator (Electric Control Head)

### Part Number – H4-031-000

The Electric control heads is an electromechanical device mounted on the master cylinder actuation port. On receiving an 24 VDC signal from the fire alarm panel or other similar source. The Electric control head gets actuated and triggers the master cylinder actuation port. It also houses a manual release plunger which can be used to manually trigger the cylinder actuation port.

The actuator also has an feature of supervisory switch. The switch is integrated such a way in electric control head. That it will give signal to releasing control panel to indicate that the electric control head is removed from master cylinder actuation port.

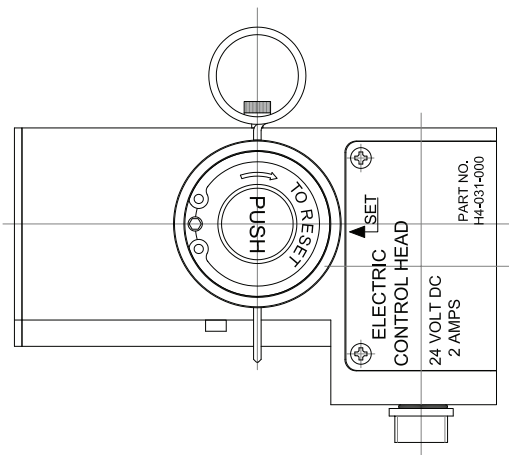

ELEVATION

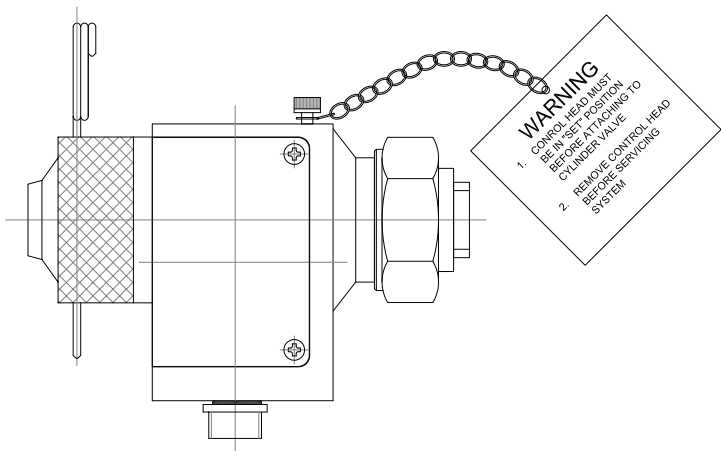
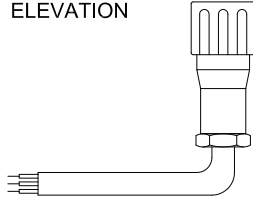

R.H.SIDE VIEW

**Technical Data :-**

Supply : 24 VDC  
 Current : 2 Amps

**Pressure Operated Control Head (Pneumatic Actuator)**

**Part Number – H4-032-000**

In multiple cylinder system, a pressure operated control head is attached to each slave cylinder at the valve actuation port. On the actuation of electric control head mounted on master cylinder, pressure from the master cylinder causes each pressure operated control head to open its attached cylinder valve pneumatically.

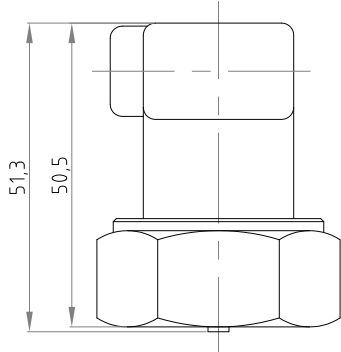

ELEVATION

**Technical Data :-**

MOC : Brass  
 Thread Type : Female NPT 1-1/4"-&-UNC-2B

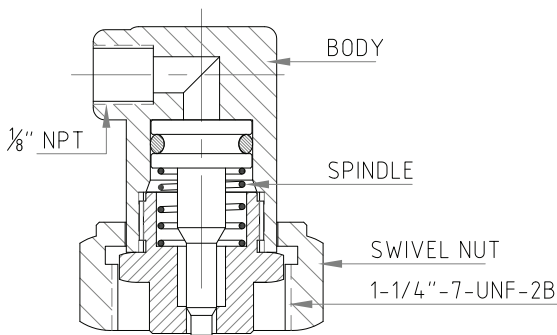

SECTION A-A

ASSEMBLY OF PRESSURE OPERATED CONTROL HEAD

## Master Cylinder Adapter Kit

### Part Number – H4-050-000

The master cylinder adapter kit provides a means of connecting a flexible actuation hose to the master and slave cylinder assembly. This enables system to actuate the Slave Clean Agent Cylinder.

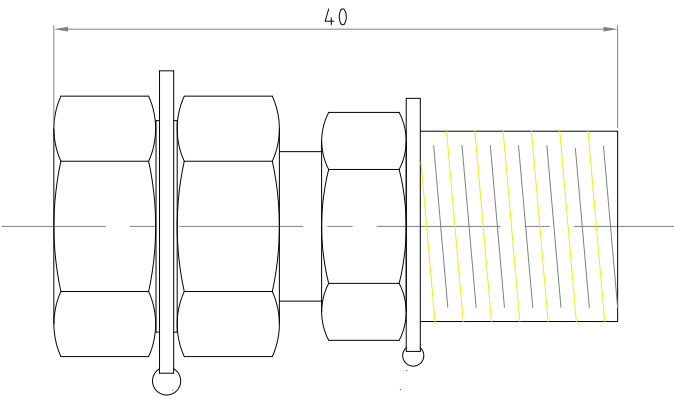

#### Technical Data :-

MOC : Brass  
Thread Type : 1/4" Male NPT

## 1/4" Pilot Actuation Male Tee and Elbow

### Male Tee, Part Number – H4-051-000

The male tee is primarily used in manifold system for connecting actuation hose from one slave cylinder to the next.

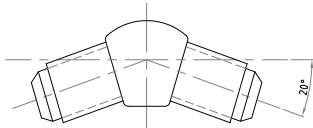

PLAN

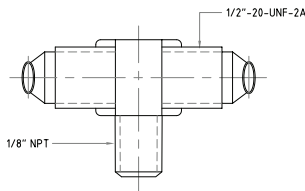

ELEVATION

### Male Elbow, Part Number – H4-052-000

The male elbow is used on the last slave cylinder in manifold system.

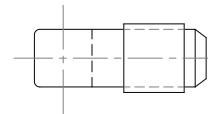

PLAN

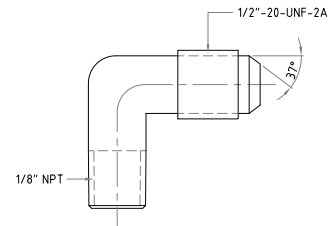

ELEVATION

## Manifold Check Valve

### 1-1/2" Valve Part Number H4-060-000

### 2" Valve Part Number H4-061-000

In a multiple cylinder arrangement where the master and slave cylinders share a common manifold or in a connected main/reserve arrangement, a manifold check valve must be placed between the discharge outlet and the discharge manifold. The manifold check valve prevents back flow from the manifold, should the system be inadvertently discharged

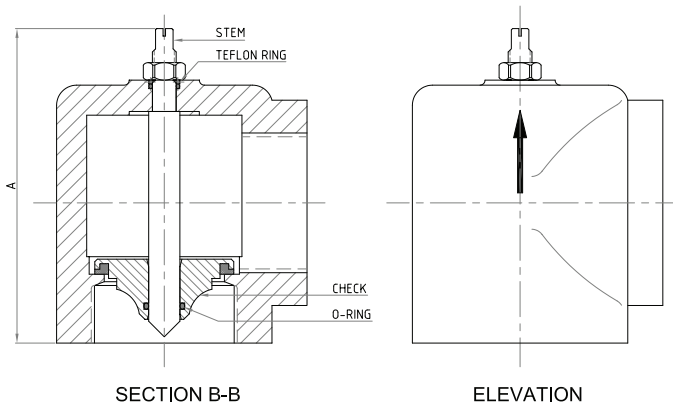

Note :-

Manifold Check valve to be installed in vertical position only.  
Please refer arrow mark during installation.

**Technical Data :-**

Valve Body : SS 316  
Check : SS 316

**180 & 360 Degree Nozzle**

360° Nozzle Part Number H5-001-XXX

180° Nozzle Part Number H5-002-XXX

FK-5-1-12 Nozzles are available in two discharge pattern 180 & 360 degree.

Discharge nozzles have a NPT female pipe thread for attachment to the discharge piping network. The nozzles are selected based on the hazard to be protected to achieve best the flow rate and distribution of FK-5-1-12 in protected hazard area

Part number / orifice for nozzle will be generated by FK-5-1-12 fire suppression system design software.

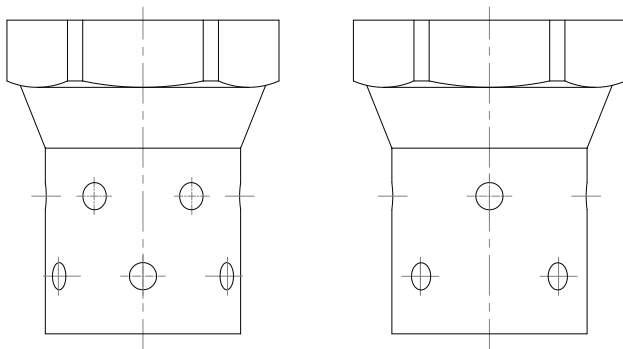

180° NOZZLE

360° NOZZLE

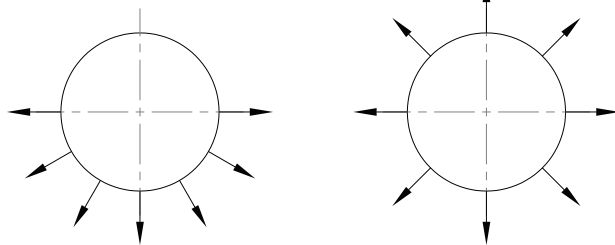

GAS FLOW DIRECTION

**Technical Data :-**

MOC : Brass  
Thread Type : Female, NPT  
Nozzle Type : 180 degree & 360 degree nozzle  
Sizes : 15NB, 20NB, 25NB, 32NB, 40NB & 50NB.

Nozzle Placement and Coverage :-

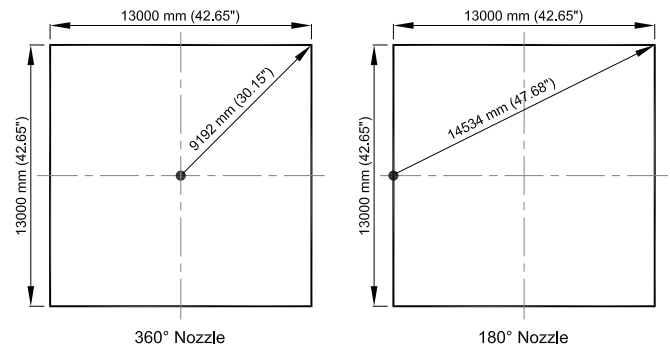

## Manifold or Piping Agent Discharge Pressure Switch

### Part Number H4-081-000

The discharge pressure switch is activated by pressure from the agent during discharge and can be used to signal an control panel that the system has discharged. The pressure switch incorporates a reset button which has to be depressed following a discharge.

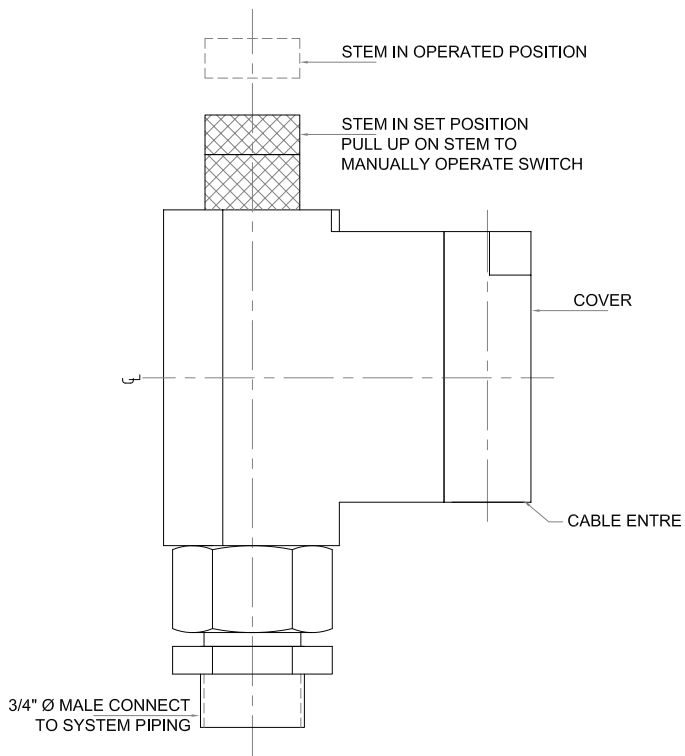

### Manifold Discharge Pressure Switch

#### Technical Data :-

Pressure Inlet Connection	: 3/4" Male
Switch Rating	: 6 Amp
Housing	: Aluminium
Switch Point	: ± 52 PSI

#### Note :-

The preferred installation position for the discharge pressure switch is upright as described in the figure.

#### For more information,

<https://honeywellbuildings.in>

Tel: +91 124 4975000

Email: [BuildingAutomation.FireIndia@honeywell.com](mailto:BuildingAutomation.FireIndia@honeywell.com)

#### Honeywell Building Automation

Unitech Trade Center, 5th Floor, Sector-43,  
Block C, Sushant Lok Phase - I,  
Gurgaon - 122 002, Haryana, India

