



OSI-R-SS Conventional Reflective Imaging Beam Smoke Detector

This conventional, single-ended beam smoke detector is easy to install – only one side needs to be wired.

Features

- Combined transmitter/receiver unit
- Wide 12° field of view
- Fast, easy, and intuitive beam alignment indicated by directional LED cross-hair arrows
- Long range coverage of 5-100 m (16-328 ft) is standard; no separate long-range kit required
- Highly resistant to building movement; tolerates +/- 1° movement
- Resistant to strong light sources; does not alarm when saturated by sunlight
- Resistant to solid object intrusion
- Automatic sensitivity threshold level setting
- 50° horizontal and 20° vertical beam adjustment
- Built-in imager heater is standard
- Remote test station capable for electronic simulated smoke test from ground level
- Standby, fault and alarm LED indicators visible from the front and bottom
- Automatic drift compensation
- Paintable housing/cover
- Removable plug-in terminal blocks
- Optional heater kit available for the reflector

Agency Listings



OSI-R-SS is a 4-wire conventional reflector-type linear optical beam smoke detector for use in fire alarm systems. The beam operates primarily on the principle of light obscuration using an infrared beam. Optical beam smoke detectors are uniquely suited to protecting buildings with large open areas with high ceilings such as a warehouse or atrium. The OSI-R-SS detector is a combined transmitter/receiver unit that can be directly connected to a conventional detector circuit.

Fast and Easy Alignment

Aligning the imager to the reflector is extremely intuitive, fast, and accurate. Both the infrared transmitter and the CMOS imager are contained in a moveable “eyeball” – an adjustable lens assembly that can move +/- 20° in the vertical direction and 50° in the horizontal direction.

Four LED arrows indicate the direction to move the lens, guiding the user to find the imager’s perfect alignment with the reflector. Once the optimum alignment is found, indicated by all green arrows, the lens is locked with a slide lever. A paintable cover is then placed over the front to secure the lever in locked position.

Resistant to Building Movement

The infrared transmitter and receiver imager generates a beam of light towards a high-efficiency reflector. The reflector returns the beam to the receiver where the received signal is analysed. The change in the strength of the received signal when smoke enters the area between the unit and the reflector is used to determine the alarm condition. The receiver imager has a wide 12° field of view that automatically tracks the reflector in case of building movement or movement of its support structure. It is virtually impossible for the receiver to lose sight of the reflector from its field of view without structural damage being caused to the building. As a result of this operation, OSI-R-SS is highly resistant to building movement, eliminating the number one cause of false alarms and/or faults with traditional beam detectors.

Resistant to Sunlight

Optical filtering, high-speed image acquisition and intelligent software algorithms provide the OSI-R-SS system with higher levels of stability and greater resistance to high level lighting variability. This provides better resistance to sunlight in its field of view, helping to prevent false alarms when saturated by sunlight, reflected sunlight or any other very bright light sources. The worst-case scenario is for the detector to go into a trouble condition unlike other traditional beam detectors which go into alarm.

Resistant to Foreign Object Intrusion

Advanced smoke imaging techniques allow the detector to avoid false alarms from partial and sudden blockage from foreign object intrusion.

Time-saving Automatic Sensitivity Setting

Unique in the market, the sensitivity of the detector is selected and set automatically at the optimum sensitivity based on the size of the reflector measured in the field of view.

Drift Compensation

The detector incorporates automatic drift compensation, whereby the

detector will adjust its detection thresholds in line with any long-term signal reduction of the beam caused by dust or other contamination of the optical surfaces.

Equipped with Built-in Imager Heater

The imager ships standard with an internal heating option to prevent condensation on the optical surface. (External power supply required.)

Specifications

Physical/Operating Specifications	
Dimensions (Detector)	Height 6" (152.4 mm); Width 10" (254 mm); Depth 4.5" (114.3 mm)
Dimensions (Reflector)	Height 9.06" (230 mm); Width 7.87" (200 mm)
Weight (Installed)	2.48 lbs (1.12 kg)
Weight (Shipping):	3.91 lbs (1.77 kg)
Wire Gauge for Terminals	14 AWG (2.08 mm ²)
Electrical Specifications: OSI-R-SS, OSI-RA-SS	
Operating Voltage Range	10.2 to 32 VDC (12 or 24VDC nominal)
Maximum Standby Current	7 mA @ 32 VDC 11 mA @ 24 VDC 20 mA @ 12 VDC 50 mA @ 10.2 VDC
Maximum Alarm Current (LED on)	11 mA @ 32 VDC 15 mA @ 24 VDC 24 mA @ 12 VDC 54 mA @ 10.2 VDC
Environmental Specifications	
Operating Humidity Range	0 to 95% Relative Humidity, Non-condensing
Operating Temperature Range	UL-Listed for use from 32°F to 100°F (0°C to 37.8°C) Application Temperature Range: -20°C to +55°C (-4°F to 131°F)
Operational Specifications	
Protection Range	16 ft to 328 ft (5 m to 100 m)
Adjustment Angle	20 degrees vertical, 50 degrees horizontal
Sensitivity Levels	Level 1 25%, Level 2 30%, Level 3 40%, Level 4 50%
Fault Condition (Trouble)	Long-term drift reference out of 20% range, beam blockage or detector out of alignment, imager saturated.
Alignment Aid	LED directional arrows
Alarm Indicator	Local red LED and remote output
Trouble Indicator	Local yellow LED and remote trouble output
Normal Indicator	Local flashing green LED
Test/Reset Features	Local alarm test switch, local alarm reset switch, Remote test and reset switch (Compatible with RTS151 and RTS151KEY(-A) test stations), Uses OSID-R test filter.
Smoke Detector Spacing	On smooth ceilings, 30-60 feet between projected beams and not more than one-half that spacing between a projected beam and a sidewall. Other spacing may be used depending on the ceiling height, airflow characteristics, and response requirements. See NFPA 72 (S524 in Canadian applications).

Electrical Specifications: BEAMHKR

Voltage Range	15 to 32 V
Maximum Current	450 mA Max at 32 V
Power Consumption	7.7 W @ 24 V 15 W @ 32 V

Electrical Specifications: RTS151KEY(-A)

Voltage Range	10.2 to 32 VDC
Current Range	9 mA Min to 11 mA Max

Dimensions

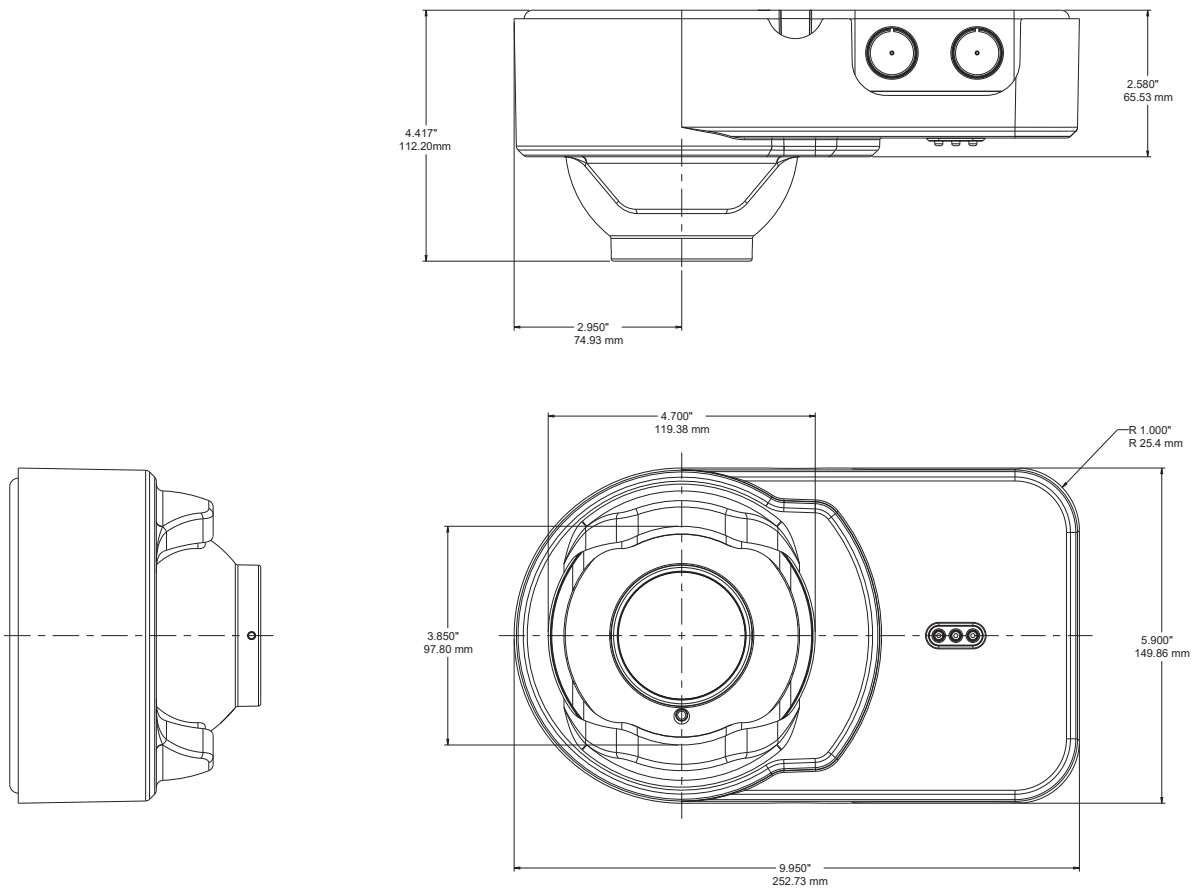

C20151-00

Ordering Information

Part No.	Description
OSI-R-SS	Conventional imaging beam smoke detector including reflector, UL listed
OSP-002	Laser alignment tool
OSP-004	Test filter, 10-pack
RTS151	Remote test station
RTS151KEY	Test and reset station with key lock, flush mount, UL listed
BEAMHKR	Heater kit for the reflector



3825 Ohio Avenue • St. Charles, IL 60174
Phone: 800-SENSOR2 • Fax: 630-377-6495

©2019 System Sensor.
Product specifications subject to change without notice. Visit systemsensor.com
for current product information, including the latest version of this data sheet.
BMDS904-01 • 1/16/2019