

HADC-2005PI / HABC-2005PI 1080P AHD VANDAL IR FIXED LENS CAMERA

- 1080P real time high resolution
- CMOS progressive scan
- True day/night capability
- Minimum illumination: 0 Lux (IR ON)
- TDN (IR-cut), AWB, AGC, Defog
- 3.6mm lens
- IR distance: upto 20 meters
- Power: 12VDC
- Vandal resistant
- Dual output AHD & CVBS



HADC-2005PI



HABC-2005PI



SYSTEM OVERVIEW

Featuring the advanced Analog High Definition (AHD) video technology, HADC-2005PI / HABC-2005PI is a HD analog camera which provides 1080P (1920 x 1080) sharp, high definition images. The AHD technology ensures real-time and non compressed signal transmission via coaxial cable, which significantly reduces installation cost and provides much sharper Images without video quality loss.

MARKET OPPORTUNITIES

The HADC-2005PI / HABC-2005PI cameras are cost effective surveillance solutions suitable for both indoor and outdoor applications, including schools, colleges, hotels, hospitals, commercial sites, retail stores, warehouses, banks and so on. Featuring 3.6mm built-in lens, 1080P resolution, TDN function and IR night vision. It is also ideal for easy and cost-effective upgrade of existing analog system to high definition surveillance.

HADC-2005PI/ HABC-2005PI

1080P AHD Vandal IR Dome Cameras

Technical Specification		
Part Code	HADC-2005PI	HABC-2005PI
System		
Video Standard	PAL/NTSC	
Scanning System	Progressive	
Image Sensor	1/2.7" 2MP CMOS Sensor	
Resolution	1080P	
Number of Pixels	1920 (H) x 1080 (V)	
Minimum Illumination	0.01Lux BW, 0Lux IR	
Video Output	AHD BNC, CVBS terminal	
Video Frame Rate	25/30 fps (PAL/NTSC)	
Sync System	Internal	
Automatic Electronic Shutter	1/25s ~ 1/50,000s(PAL), 1/30s ~ 1/60,000s(NTSC)	
Lens Type	3.6mm	
IR LEDs	18 LEDs	
IR Illumination Distance	Upto 20m, depending on scene reflectance	
SNR	≥50 db	
Day/Night	Auto with ICR	
Automatic Gain Control	Auto	
White Balance	Auto	
Digital Noise Reduction	Auto (3DNR)	
WDR	DWDR (ON/OFF)	
OSD	Yes	
Electrical		
Input Voltage	DC12V ± 10%, 500mA	
Power Consumption	6W ± 10%	
Mechanical		
Dimensions	94 x 69(H)mm	148(W) x 65(H) x 63(D)mm
Weight	400g	650g
Construction	Housing: Vandal resistant, Color: Semi-white	
Connectors	Video output: AHD BNC connector; CVBS terminal, Power input: 2.1 mm plug	
Environmental		
Operating Temperature	-10°C to 50°C	
Relative Humidity	10% to 95%, non-condensing	
IP Rating	N/A	IP66

Technical Specification

Part Code	HADC-2005PI	HABC-2005PI
Regulatory		
Certification	CE	
System Compatibility		
Compatible DVR	AHD DVR	

Note: Honeywell reserves the right, without notification, to make changes in product design and/or specifications.

DIMENSIONS

1080P AHD Vandal IR Dome Cameras

HADC-2005PI

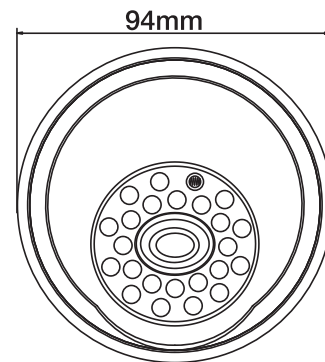
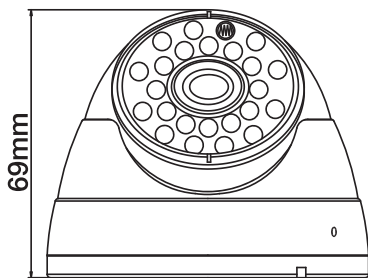

HABC-2005PI

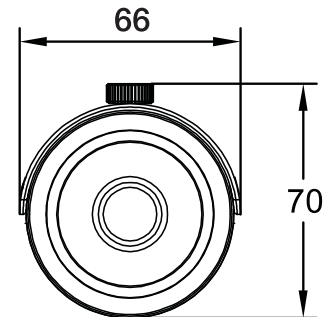
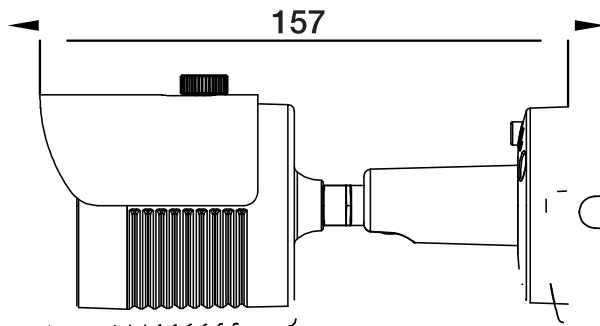

ORDERING INFORMATION

HADC-2005PI	1/2.7" CMOS Sensor, 1080P AHD, TDN, DNR, DWDR, 18 LED, 3.6mm, IR Vandal Dome Camera, Camera, 12 VDC with OSD, PAL
HABC-2005PI	1/2.7" CMOS Sensor, 1080P AHD, TDN, DNR, DWDR, 18 LED, 3.6mm, IR Vandal Bullet Camera, 12 VDC with OSD, PAL

For more information,
<https://honeywellbuildings.in>
 Call: 1-800-103-0339
 Email: HBT-Indiabuildings@honeywell.com

Honeywell HBT India Buildings
 Unitech Trade Center, 5th Floor, Sector-43,
 Block C, Sushant Lok Phase - I,
 Gurgaon - 122 002